



# BISON

OFF ROAD

## Ford Raptor 2" Lift PN: FK-2728200B

1-385-303-9599 • [www.BisonOffroad.com](http://www.BisonOffroad.com) • [info@BisonOffroad.com](mailto:info@BisonOffroad.com)

Thanks for your Bison Off Road purchase. This kit includes a lifetime warranty against defects and extends to the original purchaser only. Contact us for an immediate replacement part should they be needed. Warranties extend to active part numbers only. The Bison Offroad warranty does not extend to abuse or improper installation. Returns are allowed within 30 days of purchase. A Return Authorization Number (RA#) is required. The customer is responsible for shipping and safe packaging. Contact your retailer or wholesaler for return instructions if this product was not purchased directly from Bison Offroad.

**IMPORTANT:** The net amount of ride height increase depends upon the age and use of the vehicle, wheel offset, and numerous other factors.

**READ ALL THE INSTRUCTIONS BEFORE BEGINNING THE INSTALLATION:** Check the kit hardware against the parts list. Be sure you have all the needed parts and understand where they go. If anything is missing, do not proceed with the installation, call customer service to obtain needed items.

**WARNING:** Do not install this kit without the proper tools or on a flat surface. Vehicle may be too heavy for discount jack and small jack stands (verify rating). Even slightly sloped driveways are too dangerous to attempt installation on vehicles.

**BEFORE YOU INSTALL:** Make sure you have all the recommended tools, a flat work area and adequate lighting. Resist the urge to use tools that aren't up to the task.

✓	Qty	Description
	1	Floor Jack, Heavy Duty
	2	Jack Stands, 3 Ton Min
	2	Wheel Chocks
	1	Torque Wrench, 3/8", up to 150 FT/LBS
	1	Torque Wrench, 1/2", up to 250 FT/LBS
	1	Pry bar
	1	Safety Glasses
	1	Metric socket wrench set
	1	Metric impact socket wrench set, large
	1	Screwdriver, large
	1	Hammer, brass
	1	Impact wrench
	1	Ratcheting tie down
	1	OEM service manual
	1	Thread locker, red
	1	Paint pen or white permanent marker
	1	Note pad and pen or pencil

**NOTE:** Various types of tools are available, however, due to the extreme loads present in four-wheel drive suspension systems, we have found the two-jaw style tool that clamps to the crossmember tends to slip and damage the crossmember. A C-clamp style tool is preferred and available through tool companies such as OTC and Kent Moore.

We recommend a certified technician install this system. In addition to these instruction, professional knowledge of disassemble/reassembly procedures as well as post instructions checks must be known. Attempts to install this system without this knowledge and expertise may jeopardize the integrity and/or operating of the vehicle.

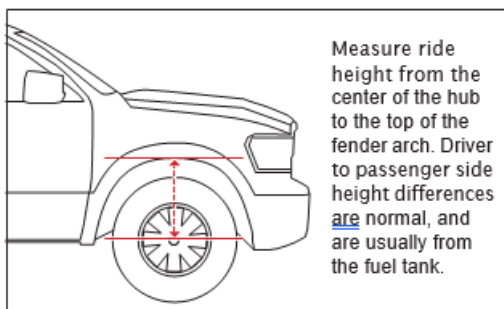

Vehicle ride height chart							
Driver Front: Stock height		Driver Rear: Stock height		Pass. Front: Stock height		Pass. Rear: Stock height	
<input type="text"/>		<input type="text"/>		<input type="text"/>		<input type="text"/>	
Lift installed		Lift installed		Lift installed		Lift installed	
<input type="text"/>		<input type="text"/>		<input type="text"/>		<input type="text"/>	
Bolt Size Millimeters	Torque Spec in FT/LBS		Bolt Size SAE	Torque Spec in FT/LBS			
	Metric Class 8.8	Metric Class 10.9		Grade 5	Grade 8		
6mm	6	8	5/16	15	20		
8mm	16	22	3/8	30	35		
10mm	40	45	7/16	45	60		
12mm	54	70	1/2	65	90		
14mm	89	117	9/16	95	130		
16mm	132	175	5/8	135	175		
18mm	182	236	3/4	185	280		



# BISON

OFF ROAD

- **Note:** The torque values are intended as a general guideline. Torque values for specific applications may vary. Bison Off Road does not warrant this information to be accurate and disclaims all liability for any claims or damage which may result from its use. See vehicle manufacturer's service manual for torque values.
- 
- **Product Use Information**
- A general rule, the taller a vehicle is the easier it will roll. We strongly recommend, because of rollover possibility, that seat belts and shoulder harness be worn at all times. Avoid situations where a side rollover may occur.
- Braking performance and capabilities are decreased when significantly large/heavier tires and wheels are used. Take this into consideration while driving, also, speedometer recalibration is necessary when larger tires are installed.
- Do not add, alter, or fabricate any factory or after-market parts which increase vehicle height over the intended height of the product purchased. Mixing component brands, lifts, and/or combining body lift with suspension lift voids all warranties. Manufacturer makes no claims regarding lifting devices and excludes any and all implied claims. We will not be responsible for any products that is altered.
- **Notice to Dealer and Vehicle Owner**
- Any vehicle equipped with any Aftermarket Product installed may have unique handling characteristics. Vehicle should have a "Warning to Driver" decal installed on the inside the windshield or on the dashboard to remind the vehicle operator of the unique handling characteristics.
- **INSTALLING DEALER:** It is your responsibility to install a warning decal and forward these instructions on to the vehicle owner for review and to be kept in the vehicle for service life.
- After installation occurs, a qualified alignment facility is required to align the vehicle to factory specs.





**BISON**  
OFF ROAD

#### Front Suspension:

1. Fully lift front suspension supported by Jack Stands on the frame or professional vehicle hoist.
2. Remove Tires.
3. Disconnect securing points for ABS, Brake Lines and Speed Sensor Wires.
4. Remove spindle nut.
5. Disconnect upper control arm, and outer tie rods from the spindle.
6. Disconnect wiring connector from shock and remove coil and shock assembly.
7. Using spring compressor, insert the spacer halves and secure collar using supplied hardware, verify that the threaded holes are pointing to the bottom of the shock.
8. Re install shock and coil assembly.
9. Using supplied \*Tree Nut Zip Tie secure the Live wire into the threaded holes on the bottom of the preload collar.
10. Attach upper control arm, tie rod, and sway bar, torque to manufacture specifications.
11. Bolt on wheels and torque to specifications
12. Cycle steering to insure there is no interference with wires or brake lines.



**BISON**  
OFF ROAD

1. Fully lift front suspension supported by Jack Stands on the frame or professional vehicle hoist.
  2. Remove Tires.
- Disconnect securing points for ABS, Brake Lines and Speed Sensor Wires.

Remove spindle nut, Upper control arm Ball Joint, outer tierod end, and Sway Bar end link.

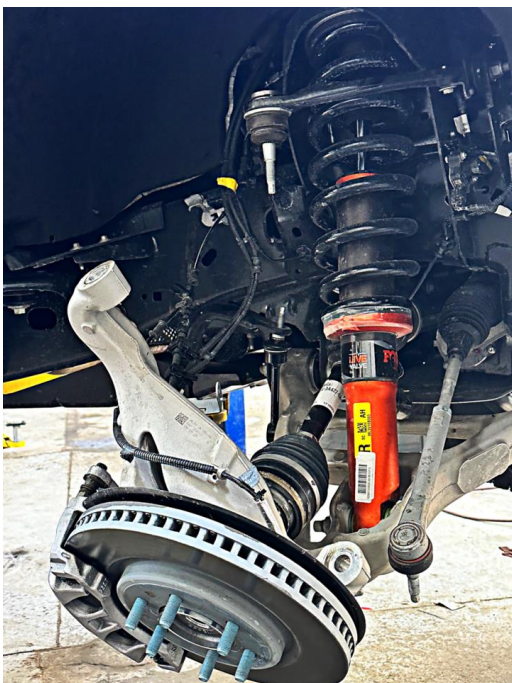
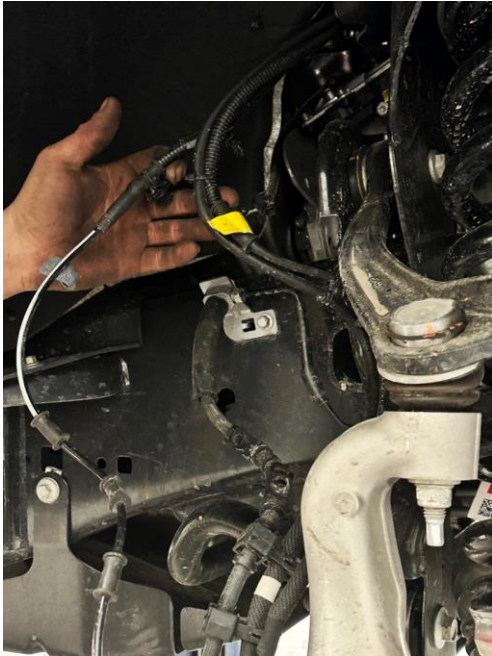





**BISON**  
OFF ROAD

Using spring compressor, insert the 1-inch spacer halves and secure collar using supplied hardware.



Install pre-load collars with thin edge pointing towards the coil



Re install Shock in the reverse order of removal.



Using supplied hardware Tree Nut Zip Tie clamp in the threaded holes on the leading edge of the pre-load spacer. Re-install wiring connectors for shock and secure brake lines.

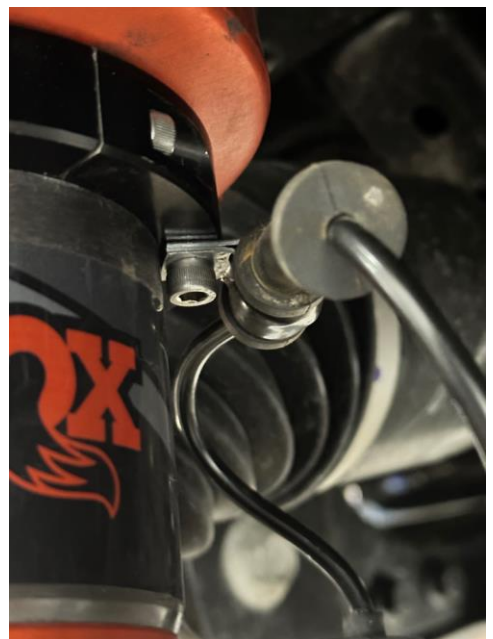



**BISON**  
OFF ROAD

**Post Installation:**

- 1. Fastener torque:** Check all fasteners for proper torque. Check to ensure for adequate clearance between all rotating, mobile, fixed, and heated members. Verify clearance between exhaust and brake lines, tire sidewalls, fuel lines, fuel tank, floorboards and wiring harness. Check steering gear for clearance. Test and inspect brake system. Mark all fasteners using a paint pen or permanent marker by putting a stripe across the fastener head down to and on the adjacent mounting surface providing a visual cue to fastener movement.
- 2. Steering sweep:** Perform steering sweep to ensure front brake hoses have adequate slack and do not contact any rotating, mobile, or heated members. Inspect rear brake hoses at full extension for adequate slack. Failure to perform hose check/ replacement may result in component failure.
- 3. Head lights:** Perform head light check and adjustment.
- 4. Inspection and Re-torque:** Re-torque all fasteners after 500 miles and then every 1000 miles. All components must be Inspected by a qualified professional mechanic at least every 3000 miles.
- 5. Alignment:** Lifted and leveled vehicles require an alignment to factory specifications. An alignment by a proper technician is a safety requirement and may save hundreds of dollars in the tire wear.
- 6. Test Drive:** Lifted and leveled vehicles have a higher center of gravity. While these kits allow the installation of larger wheels and tires your vehicle will ride and drive differently. Please take time to adjust to the new vehicle ride and handling. Check all work after the test drive and as a part of regular maintenance.

**CA Residents:** WARNING: Cancer and Reproductive Harm-[www.P65Warnings.ca.gov](http://www.P65Warnings.ca.gov)

